

WHELEN[®]

ENGINEERING COMPANY INC.

51 Winthrop Road
Chester, Connecticut 06412-0684
Phone: (860) 526-9504
Fax: (860) 526-4078
Internet: www.whelen.com
Sales e-mail: autosale@whelen.com
Canadian Sales e-mail: canadiansales@whelen.com
Customer Service e-mail: custserv@whelen.com

Installation Guide: L51 & L52 Series LED Beacon

Safety First

This document provides all the necessary information to allow your Whelen product to be properly and safely installed. Before beginning the installation and/or operation of your new product, the installation technician and operator must read this manual completely. Important information is contained herein that could prevent serious injury or damage.

- Proper installation of this product requires the installer to have a good understanding of automotive electronics, systems and procedures.
- If mounting this product requires drilling holes, the installer **MUST** be sure that no vehicle components or other vital parts could be damaged by the drilling process. Check both sides of the mounting surface before drilling begins. Also de-burr the holes and remove any metal shards or remnants. Install grommets into all wire passage holes.
- If this manual states that this product may be mounted with suction cups, magnets, tape or Velcro[®], clean the mounting surface with a 50/50 mix of isopropyl alcohol and water and dry thoroughly.
- Do not install this product or route any wires in the deployment area of your air bag. Equipment mounted or located in the air bag deployment area will damage or reduce the effectiveness of the air bag, or become a projectile that could cause serious personal injury or death. Refer to your vehicle owner's manual for the air bag deployment area. The User/Installer assumes full responsibility to determine proper mounting location, based on providing ultimate safety to all passengers inside the vehicle.
- For this product to operate at optimum efficiency, a good electrical connection to chassis ground must be made. The recommended procedure requires the product ground wire to be connected directly to the **NEGATIVE (-)** battery post (this does not include products that use cigar power cords).
- If this product uses a remote device for activation or control, make sure that this device is located in an area that allows both the vehicle and the device to be operated safely in any driving condition.
- Do not attempt to activate or control this device in a hazardous driving situation.
- This product contains either strobe light(s), halogen light(s), high-intensity LEDs or a combination of these lights. Do not stare directly into these lights. Momentary blindness and/or eye damage could result.
- Use only soap and water to clean the outer lens. Use of other chemicals could result in premature lens cracking (crazing) and discoloration. Lenses in this condition have significantly reduced effectiveness and should be replaced immediately. Inspect and operate this product regularly to confirm its proper operation and mounting condition. Do not use a pressure washer to clean this product.
- It is recommended that these instructions be stored in a safe place and referred to when performing maintenance and/or reinstallation of this product.
- **FAILURE TO FOLLOW THESE SAFETY PRECAUTIONS AND INSTRUCTIONS COULD RESULT IN DAMAGE TO THE PRODUCT OR VEHICLE AND/OR SERIOUS INJURY TO YOU AND YOUR PASSENGERS!**

For warranty information regarding this product, visit www.whelen.com/warranty

Mounting:

Permanent Mount:

CAUTION: Permanent mounting of this product will require drilling. It is absolutely necessary to make sure that no other vehicle components could be damaged by this process. Check both sides of the mounting surface before starting. If damage is likely, select a different mounting location.

- Use the base as a template and mark the three mounting holes off onto the mounting surface. Remove base. In the center between the three mounting holes, mark the location of the wire access hole.
- Drill mounting holes into the mounting surface with a #16 drill bit. Drill the wire access hole using a 3/8" drill bit. Remove any burrs from the wire access hole and install a rubber grommet (*customer supplied*) into the wire hole to protect the wires.
- The base seal goes between the beacon base and the mounting surface.
- Feed the wires first through the base seal and then through the cable access hole. Place the base (*with seal*) on the mounting surface and align the beacon mounting holes with the mounting holes drilled in step 2. Secure the beacon firmly to the mounting surface using the supplied #10 mounting screws.

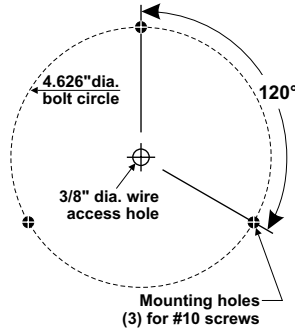

Mirror Mount (optional):

- Secure the bracket to the mirror or other part of the vehicle using the two supplied U-Bolts and elastic stop nuts.
- Secure the Beacon to the bracket using the supplied sheet metal screws and elastic stop nuts.

Magnetic Mount (optional):

WARNING: The use of any magnetically mounted warning device on the outside of a vehicle in motion is not recommended and is at the sole risk and responsibility of the user.

Magnetic: Place the beacon onto a flat, metal surface and plug it into the vehicle cigar lighter.

Wire Function:

Color	Function	Connect to:	Switch Type	Fuse @
RED	Power	+VBAT	SP/ST	3 Amp
BLK	Ground	Chassis Ground	n/a	N/A
GRY	Sync	See text	N/A	N/A
WHT/VIO	Scan-Lock™	+VBAT	MOM (N.Open)	1 Amp

WARNING! All customer supplied wires that connect to the positive terminal of the battery must be sized to supply at least 125% of the maximum operating current and FUSED at the battery to carry that load. DO NOT USE CIRCUIT BREAKERS WITH THIS PRODUCT

QTY	QTY	QTY	QTY	ITEM	PART NUMBER	DESCRIPTION
	*				01-0684972__P	LED BEACON MODEL L51
					01-0684973__P	LED BEACON MODEL L52
	*				01-06849721__M	LED BEACON MODEL L51
					01-06849731__M	LED BEACON MODEL L52
A/R	A/R	A/R	A/R	1	68-1983507-10	LENS, AMBER
A/R	A/R	A/R	A/R	2	68-1983507-30	LENS, CLEAR
1	1	1	1	3	38-0417044-00	O-RING
3	3	3	3	4		SCREW, #10 x 1" PPHSMS
-	-	-	A/R	5	01-026A531111	L51 BEACON SUB ASSEMBLY (12V)
-	-	-	A/R	6	01-026A531132	L51 BEACON SUB ASSEMBLY (24V)
-	-	A/R	-	7	01-026A531211	L52 BEACON SUB ASSEMBLY (12V)
-	-	A/R	-	8	01-026A531232	L52 BEACON SUB ASSEMBLY (24V)
-	A/R	-	-	9	01-026B101111	L51 BEACON SUB ASSEMBLY (12V)
A/R	-	-	-	10	01-026B101211	L52 BEACON SUB ASSEMBLY (12V)
1	1	1	1	11	38-0222777-00	GASKET
1	1	1	1	12	21-11091202-0	GROMMET, 3/8"

Beacon 1 Phase 1	Beacon 2 Phase 1	Beacon 1 Phase 1	Beacon 2 Phase 2	Patterns (SYNC):
				<ol style="list-style-type: none"> SignalAlert™ 75 Phase 1 SignalAlert™ 75 Phase 2 CometFlash® 75 Phase 1 CometFlash® 75 Phase 2 DoubleFlash 75 Phase 1 DoubleFlash 75 Phase 2 SingleFlash 75 Phase 1 SingleFlash 75 Phase 2 ComAlert™ 75 Phase 1 ComAlert™ 75 Phase 2 LongBurst™ 75 Phase 1 LongBurst™ 75 Phase 2 PingPong™ 75 Phase 1 PingPong™ 75 Phase 2
				Patterns (Non-SYNC) <ol style="list-style-type: none"> SingleFlash 60 SingleFlash 90 SingleFlash 120 SingleFlash 300 ComAlert™ 150 ActionFlash™ 1 ActionFlash™ 2 ModuFlash™ ActionScan™

Remember... Phase 1 always alternates with Phase 2

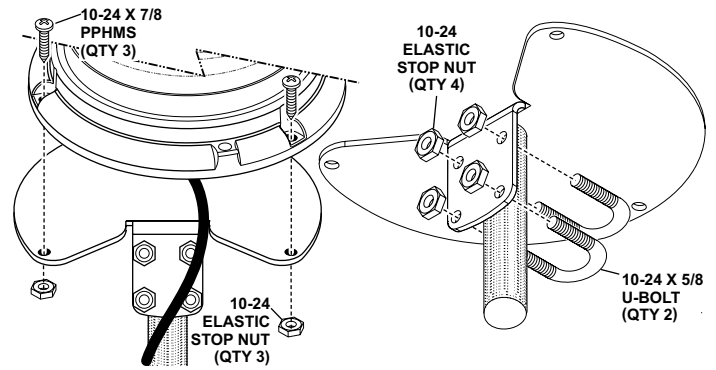

Operation:

Scan-Lock™ - Activate the RED wire to turn on the beacon. Activate the WHT/VIO wire for less than 1 second and release to cycle forward through patterns. Activating the WHT/VIO wire for more than 1 second will cause the lighthouse to cycle backward through patterns. When the desired pattern is displayed, allow it to run for more than 5 seconds. The lighthouse will now display this pattern when active. To reset to the factory default pattern, turn off power, activate the WHT/VIO wire, then turn power back on. See below for pattern information.

Sync - To sync two lighthouses, configure both lighthouses to display the same Phase 1 pattern. With the power off, connect the GREY wires from each lighthouse together. When the lighthouses are activated, their patterns will be synchronized. To configure the two lighthouses to alternate their patterns, advance the pattern of either lighthouse to the Phase 2 mode of the current pattern.

The following example will demonstrate how to use the SYNC feature with more than 2 lighthouses. In this sample system, there are 4 lighthouses. 2 are mounted on the rear, driver side of the vehicle and 2 mounted on the rear, passenger side of the vehicle.

With all the wiring complete, turn on the 4 lighthouses. As shipped from the factory, all the lighthouses will simultaneously display the same pattern (SignalAlert 75 Phase 1).

To configure, for example, the passenger side lighthouses to alternate with the driver side lighthouses, change the flash patterns for either the passenger or driver side lighthouses to Phase 2 mode of the same pattern. Do not SYNC more than 8 (eight) beacons!

IMPORTANT: It is the responsibility of the installation technician to make sure that the installation and operation of this product will not interfere with or compromise the operation or efficiency of any vehicle equipment! Before returning the vehicle to active service, visually confirm the proper operation of this product, as well as all vehicle components/equipment.

IMPORTANT WARNING!

CAUTION! DO NOT LOOK DIRECTLY AT THESE LEDS WHILE THEY ARE ON. MOMENTARY BLINDNESS AND/OR EYE DAMAGE COULD RESULT!

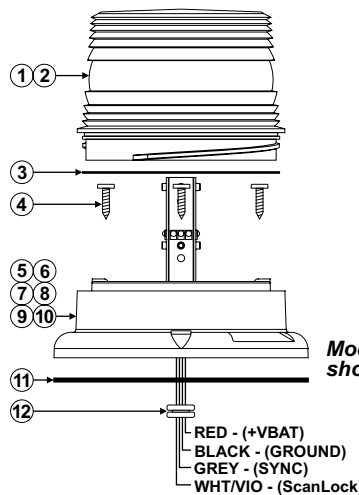

Model L51 shown.

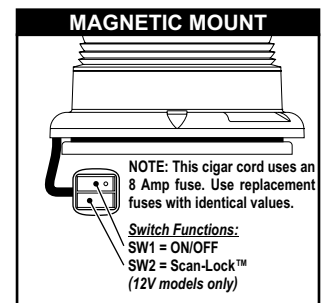

Specifications	L51		L52	
	12V	24V	12V	24V
Input Voltage	- 12.8V	25.6V	12.8V	25.6V
Input Current	-			
Peak	1.50A	0.75A	0.75A	.375A
Avg.	0.60A	0.30A	0.30A	0.15A