

TecNiq's New Surface Mounted Load Light

Lighting the area around the doors of a trailer provides safety and security. TecNiq's new compact D30 Surface Mounted Load Light provides 2,000 lumens of bright white LED light, illuminating 150 sq. ft. from a height of 10'. Built to work, it's ideal for semi-trailers, box trucks, RV toy haulers, and other vehicles and trailers with loading ramps.

Balancing power and illumination area is key with any lighting solution and the D30 delivers. Its 64° by 51° beam angle from 13.5' up brightens a space over 16' W x 12' D. Matched with its powerful 2,000 lumen output, it's more than ample for even the darkest areas.

- Extremely durable surface mounted load light
- Aluminum heat sink housing, finished in a black powder coat will keep this light looking great for years of use
- Includes a form fitting TPE gasket, which has excellent chemical and UV resistance
- 2000 lumens of bright white light
- IP68 Rated – Water & dust proof
- Surface mount installation

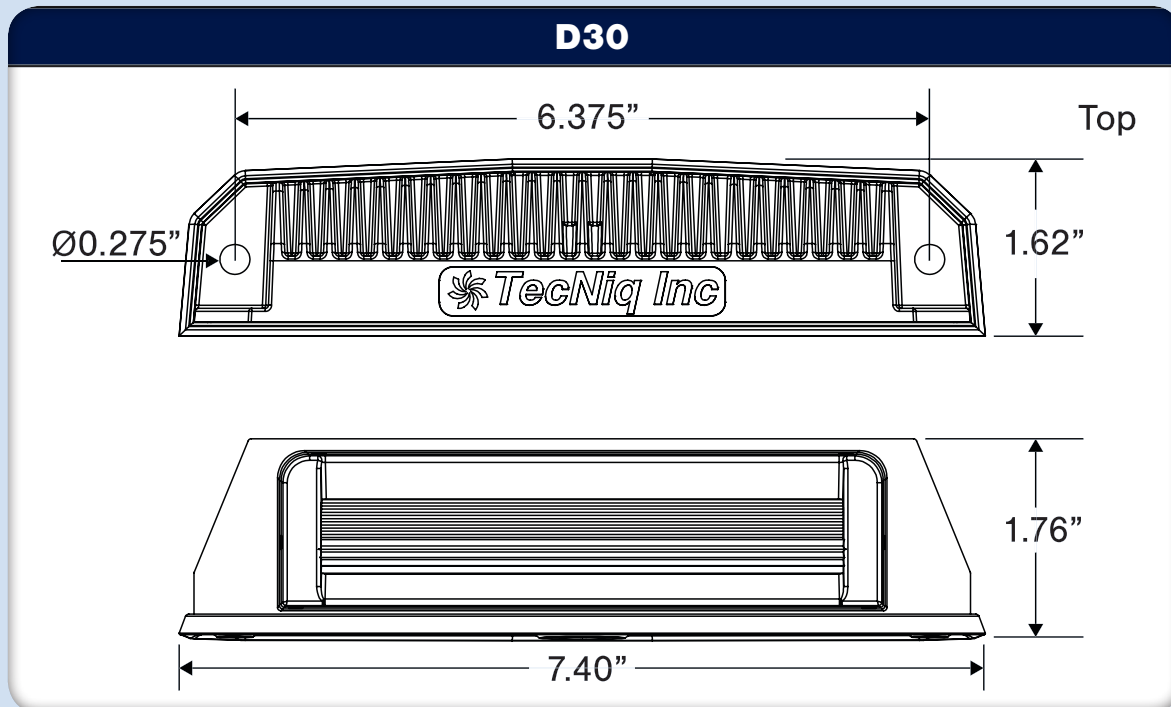

Part Number	Description	Max Amp Draw	Connector
D30-WB00-1	High Output Ramp Light Pigtail Wire	1.3A - 1.9A (12V)	12" Wire
D30-WB0B-1	LED High Output Surface Mount Load Light w/ .180" Bullets	1.3A - 1.9A (12V)	12" Wire / 0.180" Bul

IP68 rated, the D30 is completely dust and waterproof. Its rugged aluminum heat sink housing is powder-coated black for years of attractive service. The LED light includes a form-fitting TPE gasket that's UV- and chemical-resistant. It has a maximum draw of 1.3–1.9 amps. The D30 has a small footprint so it'll fit almost anywhere. It's 7.4" L x 1.62" W x 1.76" H and mounts easily with two screws.