



- universal mounting
- built-in RFI filters
- solid state power supply
- 10,000 hour strobe lamp
- five year warranty on power supply
- one year warranty on lamp
- available in six lens colors
- UL listed (AC models only)
- NEMA 4X
- 1200 ECP

824 MULTI STROBE

Medium Profile - Double or Quad Flash Warning Light

The model 824 family is a medium profile, multi-flash strobe light which can be changed by the customer from double flash to quad flash operation. It features universal mounting, full size 360° Lexan® lens, high efficiency regulated solid state power supply, and heavy duty xenon strobe lamp. DC units have polarity protection and built-in filters to protect against radio interference and spike voltages. AC units are designed to withstand multiple line transient spikes of 6000V without damage. The model 824 strobe features a fully potted, Lexan®, multi-purpose mounting base which is vibration and water resistant, and has a plug-in strobe lamp and photocell which can be activated to automatically reduce intensity during nighttime operation.

Lens Colors

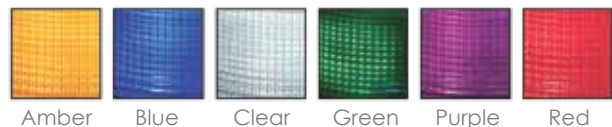

Ordering Information

Please specify lens colors and model number when ordering. Available colors are Amber, Blue, Clear, Green, Purple and Red.

Model No.	Description	Voltage/Frequency
824-110	AC strobe with 10" leads, UL listed	120VAC, 50/60Hz
824LC-110	AC strobe with AC cord set, UL listed	120VAC, 50/60Hz
824-240	AC strobe with 10" leads, UL listed	240VAC, 50/60Hz
824-1228	DC strobe with 10" leads	12 - 28VDC
824MB-1228	DC strobe with magnetic mount and 10' coil cord	12 - 28VDC
824MBSC-1228	DC strobe with magnetic mount and 10' straight cord	12 - 28VDC

824 MULTISTROBE

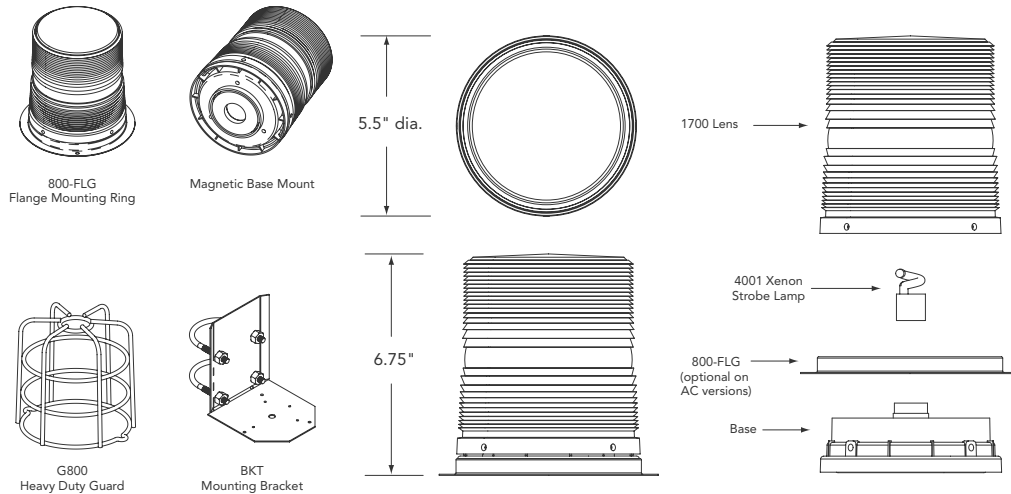

Specifications

Item	Description
Flash Rate	68 to 72 double flashes per minute 58 to 62 quad multi-flashes per minute
Light Output	1020 effective candlepower (ECP)* (Double flash) 1200 effective candlepower (ECP)* (Quad flash)
Voltage and Amperage	12-28VDC draws 2.2 to 2.4A @ 12V tapering to 1.2 to 1.4A @ 28V at hi intensity 120VAC draws 0.8A peak, 0.5 to 0.6A average 240VAC draws 0.8A peak, 0.5 to 0.6A average
Power Supply Output @ 240V Input	17 joules per double flash. 1,700,000 Peak Candlepower** 25 joules per quad multi-flash. 2,500,000 Peak Candlepower**
Operating Temperature	-40 C to 65 C
Size and Weight	6.75" tall x 5.5" dia. x 2.2 lbs (171mm x 140mm x 1.06kg)
Encapsulation	Fully potted in urethane material with no exposure to High Voltage possible

Available Options

NOTE: All "/" options are factory installed only.

Model No.	Description
BKT	Mounting bracket
/LBO-MAXI	Lens blackout segment 180°
800/1250-DC	Clear lens dust cover
G800	Heavy duty guard
TBO-MAXI	Top lens blackout
800-FLG	Chrome flange mounting ring (standard on DC versions, optional on AC versions)

Replacement Parts

Model No.	Description
4001	Xenon strobe lamp
1700	Color lens (please specify color)
824-110-BASE	120VAC power supply
824LC-BASE	120VAC power supply with AC cord set
824-240-BASE	208/240VAC power supply
824-1228-BASE	12-28VDC power supply
824MB-BASE	12-28VDC power supply with magnetic mount and coil cord
824MB-SCBASE	12-28VDC power supply with magnetic mount and straight cord

Architect and Engineer Specifications

The visual signaling beacon shall be Tomar model 824 or approved equal. The light source shall be a plug-in field replaceable xenon strobe lamp. The beacon shall have a field selectable double or quad flash rate of 68 to 72 double flashes per minute, or 58 to 62 quad flashes per minute. The warning beacon shall have a Lexan® lens and universal mount base. The DC voltage units are to have polarity protection, and must have built-in RFI filters to protect against radio interference and spike voltages. All beacons must have fully potted power supply and base. The AC units shall be designed to withstand multiple line transient spikes of 6000V without damage. Light intensity is to be 1020 effective candelas in double-flash mode, and 1200 effective candelas in quad-flash mode. Voltage ranges shall be 12-28VDC, 120 VAC, and 240VAC. Strobe light shall be designed to accept a dome guard and mounting bracket.

*ECP (Effective Candlepower) is the intensity that would appear to an observer if the light were burning steadily.

**Peak Candlepower is the maximum light intensity generated by a flashing light during its light pulse.