

WHELEN[®]

ENGINEERING COMPANY INC.

51 Winthrop Road
Chester, Connecticut 06412-0684
Phone: (860) 526-9504
Fax: (860) 526-4078
Internet: www.whelen.com
Sales e-mail: autosale@whelen.com
Canadian Sales e-mail: canadiansales@whelen.com
Customer Service e-mail: custserv@whelen.com

Installation Guide:
L10 Super-LED[®] Beacon
(12 and 24 volt)
Models L10H, L10H**4, L10L** and L10L**4**

Warnings to Installers

Whelen's emergency vehicle warning devices must be properly mounted and wired in order to be effective and safe. Read and follow all of Whelen's written instructions when installing or using this device. Emergency vehicles are often operated under high speed stressful conditions which must be accounted for when installing all emergency warning devices. Controls should be placed within convenient reach of the operator so that he can operate the system without taking his eyes off the roadway. Emergency warning devices can require high electrical voltages and/or currents. Properly protect and use caution around live electrical connections. Grounding or shorting of electrical connections can cause high current arcing, which can cause personal injury and/or vehicle damage, including fire. Many electronic devices used in emergency vehicles can create or be affected by electromagnetic interference. Therefore, after installation of any electronic device it is necessary to test all electronic equipment simultaneously to insure that they operate free of interference from other components within the vehicle. Never power emergency warning equipment from the same circuit or share the same grounding circuit with radio communication equipment. All devices should be mounted in accordance with the manufacturer's instructions and securely fastened to vehicle elements of sufficient strength to withstand the forces applied to the device. Driver and/or passenger air bags (SRS) will affect the way equipment should be mounted. This device should be mounted by permanent installation and within the zones specified by the vehicle manufacturer, if any. Any device mounted in the deployment area of an air bag will damage or reduce the effectiveness of the air bag and may damage or dislodge the device. Installer must be sure that this device, its mounting hardware and electrical supply wiring does not interfere with the air bag or the SRS wiring or sensors. Mounting the unit inside the vehicle by a method other than permanent installation is not recommended as unit may become dislodged during swerving; sudden braking or collision. Failure to follow instructions can result in personal injury. Whelen assumes no liability for any loss resulting from the use of this warning device. **PROPER INSTALLATION COMBINED WITH OPERATOR TRAINING IN THE PROPER USE OF EMERGENCY WARNING DEVICES IS ESSENTIAL TO INSURE THE SAFETY OF EMERGENCY PERSONNEL AND THE PUBLIC.**

Warnings to Users

Whelen's emergency vehicle warning devices are intended to alert other operators and pedestrians to the presence and operation of emergency vehicles and personnel. However, the use of this or any other Whelen emergency warning device does not guarantee that you will have the right-of-way or that other drivers and pedestrians will properly heed an emergency warning signal. Never assume you have the right-of-way. It is your responsibility to proceed safely before entering an intersection, driving against traffic, responding at a high rate of speed, or walking on or around traffic lanes. Emergency vehicle warning devices should be tested on a daily basis to ensure that they operate properly. When in actual use, the operator must ensure that both visual and audible warnings are not blocked by vehicle components (i.e.: open trunks or compartment doors), people, vehicles, or other obstructions. It is the user's responsibility to understand and obey all laws regarding emergency warning devices. The user should be familiar with all applicable laws and regulations prior to the use of any emergency vehicle warning device. Whelen's audible warning devices are designed to project sound in a forward direction away from the vehicle occupants. However, because sustained periodic exposure to loud sounds can cause hearing loss, all audible warning devices should be installed and operated in accordance with the standards established by the National Fire Protection Association.

Safety First

This document provides all the necessary information to allow your Whelen product to be properly and safely installed. Before beginning the installation and/or operation of your new product, the installation technician and operator must read this manual completely. Important information is contained herein that could prevent serious injury or damage.

- **Proper installation of this product requires the installer to have a good understanding of automotive electronics, systems and procedures.**
- **Whelen Engineering requires the use of waterproof butt splices and/or connectors if that connector could be exposed to moisture.**
- **Failure to use specified installation parts and/or hardware will void the product warranty.**
- **If mounting this product requires drilling holes, the installer MUST be sure that no vehicle components or other vital parts could be damaged by the drilling process. Check both sides of the mounting surface before drilling begins. Also de-burr the holes and remove any metal shards or remnants. Install grommets into all wire passage holes.**
- **If this manual states that this product may be mounted with suction cups, magnets, tape or Velcro[®], clean the mounting surface with a 50/50 mix of isopropyl alcohol and water and dry thoroughly.**
- **Do not install this product or route any wires in the deployment area of your air bag. Equipment mounted or located in the air bag deployment area will damage or reduce the effectiveness of the air bag, or become a projectile that could cause serious personal injury or death. Refer to your vehicle owner's manual for the air bag deployment area. The User/Installer assumes full responsibility to determine proper mounting location, based on providing ultimate safety to all passengers inside the vehicle.**
- **For this product to operate at optimum efficiency, a good electrical connection to chassis ground must be made. The recommended procedure requires the product ground wire to be connected directly to the NEGATIVE (-) battery post (this does not include products that use cigar power cords).**
- **If this product uses a remote device for activation or control, make sure that this device is located in an area that allows both the vehicle and the device to be operated safely in any driving condition.**
- **Do not attempt to activate or control this device in a hazardous driving situation.**
- **This product contains either strobe light(s), halogen light(s), high-intensity LEDs or a combination of these lights. Do not stare directly into these lights. Momentary blindness and/or eye damage could result.**
- **Use only soap and water to clean the outer lens. Use of other chemicals could result in premature lens cracking (crazing) and discoloration. Lenses in this condition have significantly reduced effectiveness and should be replaced immediately. Inspect and operate this product regularly to confirm its proper operation and mounting condition. Do not use a pressure washer to clean this product.**
- **It is recommended that these instructions be stored in a safe place and referred to when performing maintenance and/or reinstallation of this product.**
- **FAILURE TO FOLLOW THESE SAFETY PRECAUTIONS AND INSTRUCTIONS COULD RESULT IN DAMAGE TO THE PRODUCT OR VEHICLE AND/OR SERIOUS INJURY TO YOU AND YOUR PASSENGERS!**

Specifications:

12V

Input Voltage 12.8 VDC +/- 20%
 Input Current / Peak 1 AMP
 Input Current / Avg 0.4 AMPS

24V

Input Voltage 25.6 VDC +/- 20%
 Input Current / Peak 0.5 AMPS
 Input Current / Avg 0.2 AMPS

Permanent Mount:

- Using the base as a template, mark the 3 mounting holes onto the mounting surface. Remove the base and mark the location of the wire access hole, centered between the 3 mounting holes.
- Drill the mounting holes using a drill bit sized for a #10 screw. Drill a wire access hole using a 3/8" drill bit. Remove the burrs from the wire access hole so as not to damage the wires. It is recommended that a rubber grommet be installed to further protect the wires. A gasket will be used between the beacon base and the mounting surface.
- After connecting the beacon to the power cable, feed the wires through the cable access hole and place the base and gasket on the mounting surface. Align the mounting holes in the base with the mounting holes in the mounting surface. Secure beacon firmly to the mounting surface using the #10 X 5/8 Sheet Metal Screws provided.

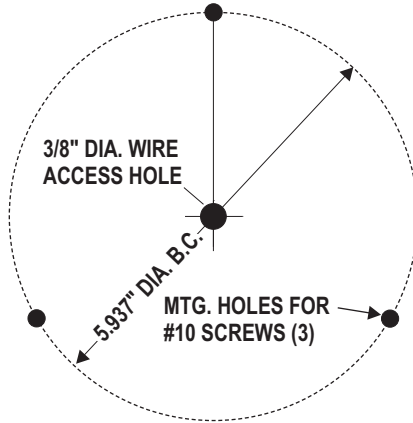

**MOUNTING DIMENSIONS
 PERMANENT MOUNT**

1 Inch (NPT) Pipe Mount:

Threading for a 1" NPT pipe mounting is precast into the base. Feed the power cable through the 1" pipe and connect to wires of beacon. Screw the beacon to the threads on the pipe, taking precaution not to damage the power wires. **NOTE: Do not tighten the base too hard so as not to damage the threads.**

Temporary Mount (Magnetic, Suction Cup, etc.)

With the magnetic or magnetic/suction cup mounting options you will be able to mount your beacon so that you can remove it if necessary and avoid drilling.

Magnetic/suction: Thoroughly clean the proposed mounting surface prior to mounting. For suction cup mounting, wipe the suction cup clean, place the beacon onto its mounting surface and apply gentle pressure to ensure a good seal has been achieved. The Magnetic/Suction Cups mount the same way as standard suction cups but are best suited to a flat, steel surface.

Magnetic: Place the beacon onto the mounting surface and plug it into the vehicle cigar lighter.

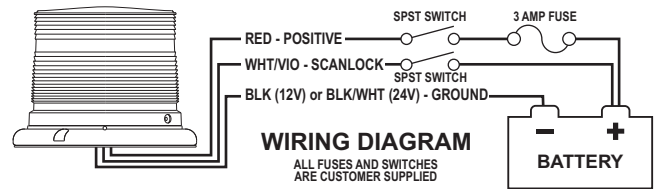

Wiring:

WARNING! All customer supplied wires that connect to the positive terminal of the battery must be sized to supply at least 125% of the maximum operating current and FUSED at the battery to carry the load. DO NOT USE CIRCUIT BREAKERS WITH THIS PRODUCT!

This product is polarity sensitive. If the positive and negative wires are reversed the unit will not function. Fuse the positive (RED) wire @ 3 Amps at the battery.

- Connect the RED wire to positive voltage (+VBAT). A customer supplied single pole/single throw (SPST) switch may be used to control the ON/OFF function of the beacon.
- Connect the BLK or BLK/WHT wire to chassis ground.

Operation:

Scan-Lock™ (White/Violet):

To use Scan-Lock™, the beacon must be turned on:

TO CHANGE PATTERNS: To cycle forward to the next available pattern apply +VBAT to the WHT/VIO wire for less than 1 second and release. To cycle back to the previous pattern apply +VBAT to the WHT/VIO wire for more than 1 second and release.

TO CHANGE THE DEFAULT PATTERN: When the desired pattern is displayed, allow it to run for more than 5 seconds. The beacon will now display this pattern when initially activated.

TO RESTORE THE FACTORY DEFAULT PATTERN: With the power to the beacon off, apply +VBAT to the WHT/VIO wire. Turn power to the beacon on. The factory default pattern should now be displayed.

A normally open momentary switch can be used to control Scan-Lock™ operation.

Flash Patterns:

- | | | |
|--------------------|---------------------|---------------------|
| 1. SignalAlert™ 75 | 7. PingPong™ 75 | 13. ComAlert™ 150 |
| 2. CometFlash® 75 | 8. SingleFlash 60 | 14. ActionFlash™ 50 |
| 3. DoubleFlash 75 | 9. SingleFlash 90 | 15. ActionFlash 150 |
| 4. SingleFlash 75 | 10. SingleFlash 120 | 16. ModuFlash™ |
| 5. ComAlert™ 75 | 11. SingleFlash 300 | 17. ActionScan™ |
| 6. LongBurst™ 75 | 12. DoubleFlash 150 | 18. Steady |

IMPORTANT WARNING!

CAUTION! DO NOT LOOK DIRECTLY AT THESE LED'S WHILE THEY ARE ON. MOMENTARY BLINDNESS AND/OR EYE DAMAGE COULD RESULT!

IMPORTANT: It is the responsibility of the installation technician to make sure that the installation and operation of this product will not interfere with or compromise the operation or efficiency of any vehicle equipment! Permanent mounting of this product will require drilling. It is absolutely necessary to make sure that no other vehicle components could be damaged by this process. Check both sides of the mounting surface before starting. If damage is likely, select a different mounting location.

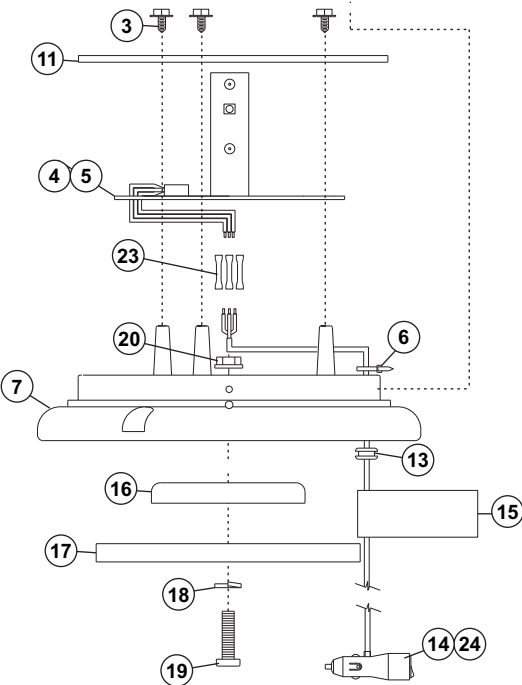
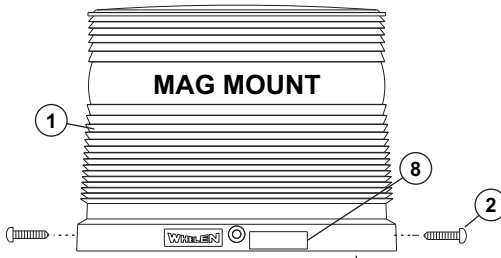
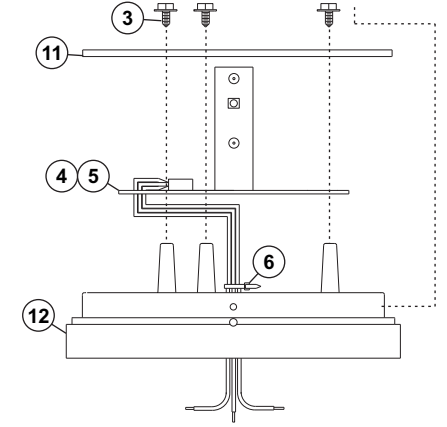
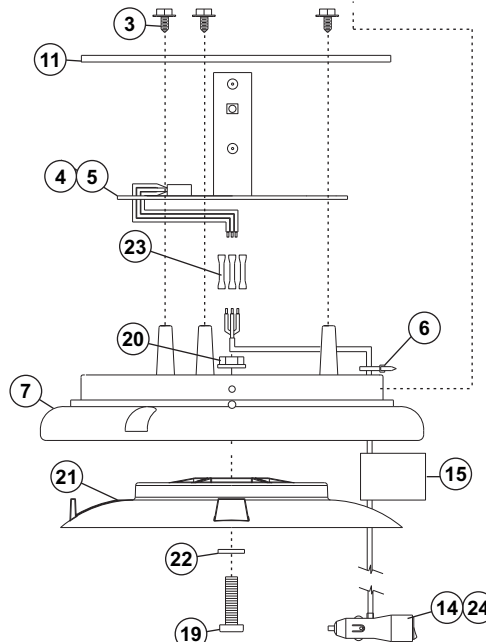
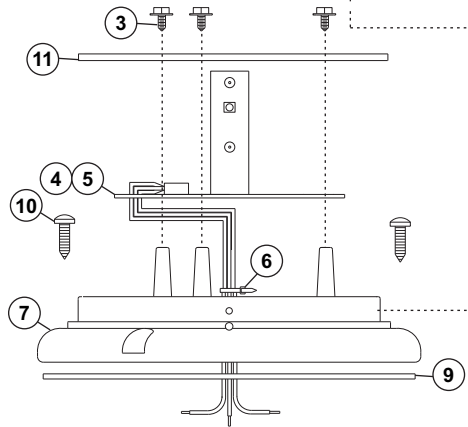
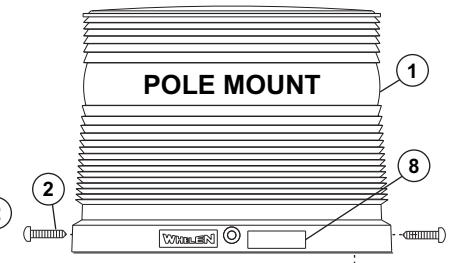
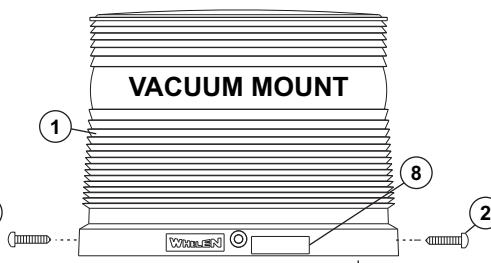
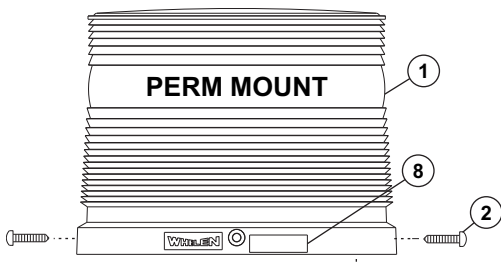

QTY	QTY	QTY	QTY	ITEM	PART NUMBER	DESCRIPTION
		*			01-0687236-__	LED LIGHT ASSY, L10, PERMANENT MOUNT
		*			01-06872361__	LED LIGHT ASSY, L10, POLE MOUNT
		*			01-06872362__	LED LIGHT ASSY, L10, MAG MOUNT
	*				01-06872363__	LED LIGHT ASSY, L10, VACUUM MOUNT
1	1	1	1	1	68-2187135-__	DOME, AMBER OPTIC DMS LED BEACON
2	2	2	2	2	15-065419-080	SCREW, 6 X 1/2 PPH PLASTI 410 SS
3	3	3	3	3	15-066939-056	#6 X 5/16" HEX WSHR HD. THD. FORMING SCREW
A/R	A/R	A/R	A/R	4	01-026D444-__1	ELEC ASSY, L10 12V BALLAST WITH LEDS
A/R	A/R	A/R	A/R	5	01-026D444-__2	ELEC ASSY, L10 24V BALLAST WITH LEDS
1	1	1	1	6	26-0215001-03	TY WRAP, 3" BLACK
1	1	-	1	7	06-181468-001	BASE, STROBE, PLASTIC
1	1	1	1	8	10-0523796-__	LABEL
-	-	-	1	9	38-0241596-00	SEAL, BASE MODEL 2000 SERIES B
-	-	-	3	10	15-101416-100	SCREW, 10 X 5/8 PPHSMS .410 SS
1	1	1	1	11	38-0441331-00	O RING, ROTATING BEACON
-	-	1	-	12	06-182589-001	BASE, MODEL 800 FLANGELESS AS MOLDED
-	1	-	-	13	21-11091202-0	GROMMET, 3/8" #905
A/R	A/R	-	-	14	69-1343576-18	CORD, CIGAR PLUG STRAIGHT 10 #18/3 DUAL SWITCH 8 AMP FUSE
1	1	-	-	15	10-0322783-02	LABEL, AIRBAG & MAG MT WARNING
-	1	-	-	16	65-0010192-00	MAGNET, X-80 NEW DMS (RB80) NICKLE PLATED
-	1	-	-	17	38-0143340-00	PAD, MOUNTING MAGNET MOUNT
-	1	-	-	18	16-1331520-65	WASHER, 1/4 SPLIT LOCK
1	1	-	-	19	14-130216-160	SCREW, 1/4-20 X 1" PPHMS SS
1	1	-	-	20	13-130111-073	NUT, 1/4-20 WIZ CAD PLATED
1	-	-	-	21	08-1583927-05	SUCTION CUP, MAGNET MOUNT
1	-	-	-	22	16-1302820-06	WASHER, FLAT 1/4" 7/8 OD SS 17/64 ID .056-.070" THK
3	3	-	-	23	25-0510223-05	BUTT TERM, 22-16 GA, INS
A/R	A/R	-	-	24	69-1343576-2G	CORD, CIGAR PLUG STRAIGHT 10 #20/3 DUAL SWITCH 8A GRN LED

PART NUMBER KEY
 - = PERM 2 = MAG 0 = 12V
 1 = POLE 3 = VAC 1 = 24V
DOME/LED COLOR
 A = AMBER/AMBER R = RED/RED 3 = CLEAR/WHITE
 B = BLUE/BLUE 1 = CLEAR/AMBER 4 = CLEAR/GREEN
 G = GREEN/GREEN 2 = CLEAR/BLUE 5 = CLEAR/RED

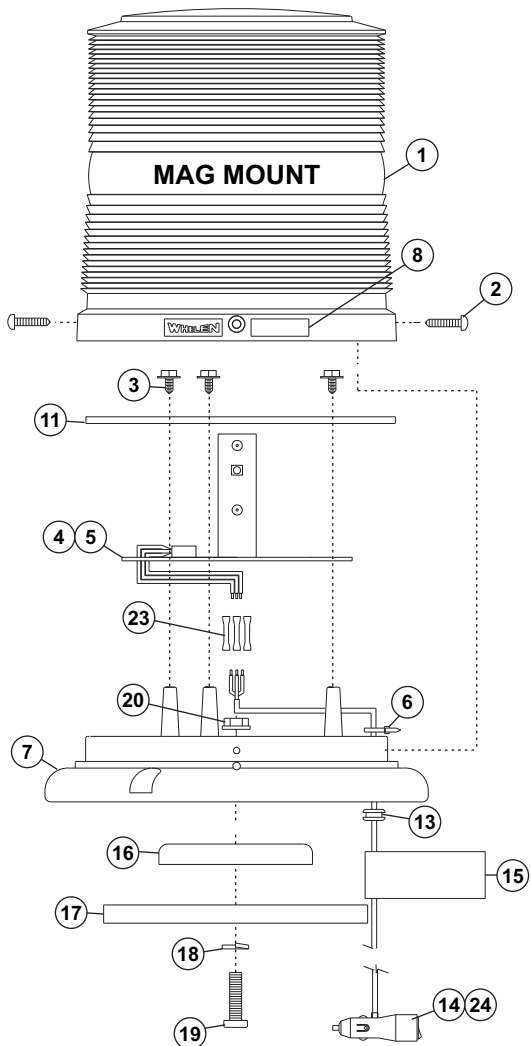
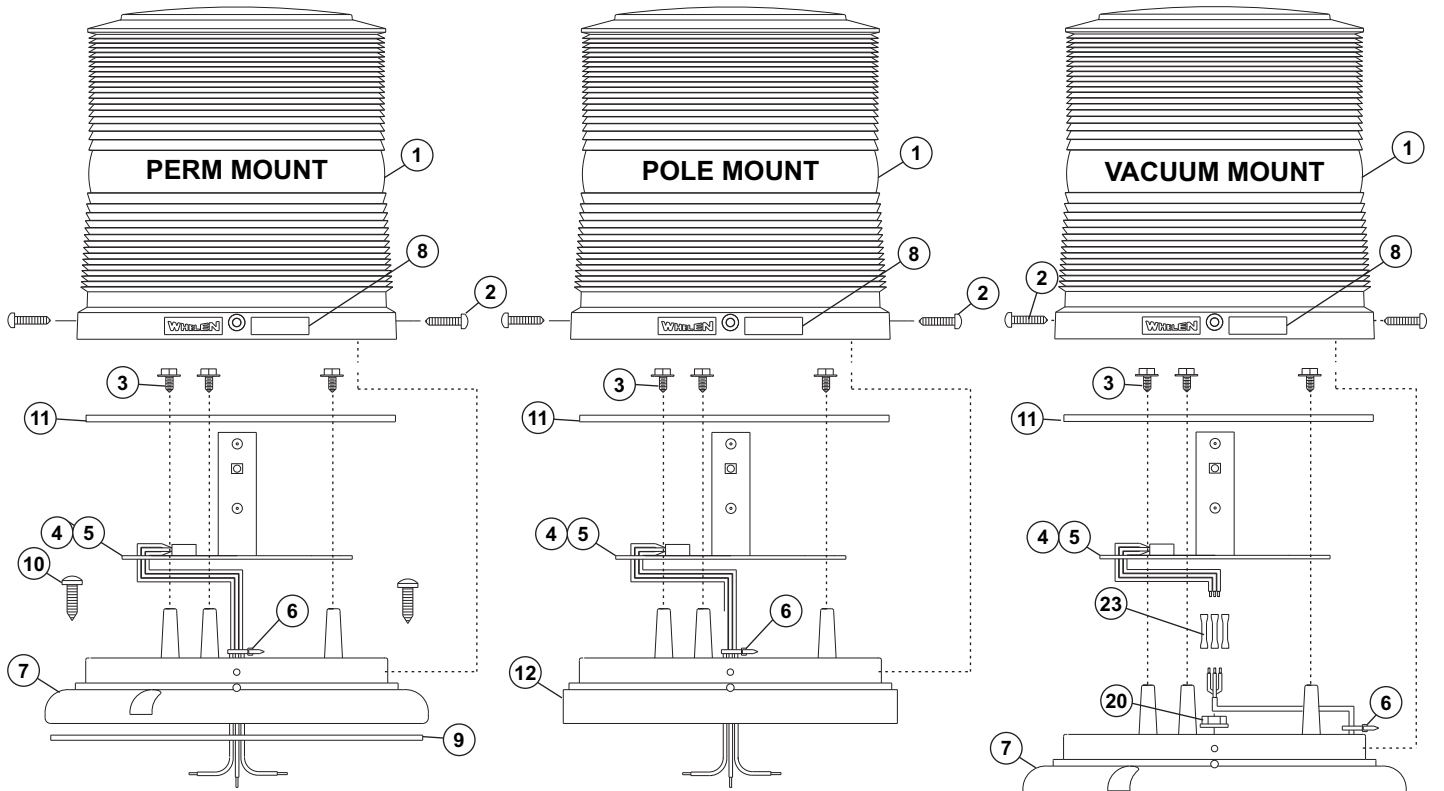

QTY	QTY	QTY	QTY	ITEM	PART NUMBER	DESCRIPTION
		*			01-0687038-__	LED LIGHT ASSY, L10, PERMANENT MOUNT
		*			01-06870381-__	LED LIGHT ASSY, L10, POLE MOUNT
	*				01-06870382-__	LED LIGHT ASSY, L10, MAG MOUNT
*					01-06870383-__	LED LIGHT ASSY, L10, VACUUM MOUNT
1	1	1	1	1	68-2180483-__	DOME, LENS (SAE) WITH WHELEN LOGO
2	2	2	2	2	15-065419-080	SCREW, 6 X 1/2 PPH PLASTI 410 SS
3	3	3	3	3	15-066939-056	#6 X 5/16" HEX WSHR HD. THD. FORMING SCREW
A/R	A/R	A/R	A/R	4	01-026D444-__1	ELEC ASSY, L10 12V BALLAST WITH LEDS
A/R	A/R	A/R	A/R	5	01-026D444-__2	ELEC ASSY, L10 24V BALLAST WITH LEDS
1	1	1	1	6	26-0215001-03	TY WRAP, 3" BLACK
1	1	-	1	7	06-181468-001	BASE, STROBE, PLASTIC
1	1	1	1	8	10-0526192-__	LABEL
-	-	-	1	9	38-0241596-00	SEAL, BASE MODEL 2000 SERIES B
-	-	-	3	10	15-101416-100	SCREW, 10 X 5/8 PPHSMS 410 SS
1	1	1	1	11	38-0441331-00	O RING, ROTATING BEACON
-	-	1	-	12	06-182589-001	BASE, MODEL 800 FLANGELESS AS MOLDED
-	1	-	-	13	21-11091202-0	GROMMET, 3/8" #905
A/R	A/R	-	-	14	69-1343576-18	CORD, CIGAR PLUG STRAIGHT 10' #183 DUAL SWITCH 8 AMP FUSE
1	1	-	-	15	10-0322783-02	LABEL, AIRBAG & MAG MT WARNING
-	1	-	-	16	65-0010192-00	MAGNET, X-80 NEW DMS (RB80) NICKLE PLATED
-	1	-	-	17	38-0143340-00	PAD, MOUNTING MAGNET MOUNT
-	1	-	-	18	16-1331520-65	WASHER, 1/4 SPLIT LOCK
1	1	-	-	19	14-130216-160	SCREW, 1/4-20 X 1" PPHMS SS
1	1	-	-	20	13-130111-073	NUT, 1/4-20 WIZ CAD PLATED
1	-	-	-	21	08-1583927-05	SUCTION CUP, MAGNET MOUNT
1	-	-	-	22	16-1302820-06	WASHER, FLAT 1/4" 7/8 OD SS 17/64 ID .056-.070" THK
3	3	-	-	23	25-0510223-05	BUTT TERM, 22-16 GA, INS
A/R	A/R	-	-	24	69-1343576-2G	CORD, CIGAR PLUG STRAIGHT 10' #203 DUAL SWITCH 8A GRN LED

PART NUMBER KEY
 01-0687038-__

MOUNTING	VOLTAGE	DOME/LED COLOR
-- = PERM 2 = MAG	0 = 12V	A = AMBER/AMBER R = RED/RED 3 = CLEAR/WHITE
1 = POLE 3 = VAC	1 = 24V	B = BLUE/BLUE 1 = CLEAR/AMBER 4 = CLEAR/GREEN
		G = GREEN/GREEN 2 = CLEAR/BLUE 5 = CLEAR/RED